



By
Heat Design

Models
1250T / 1600T

Please read the instructions carefully before installation and keep for future reference.

Please Note:

This product is for a well-insulated dwelling.

Table of Contents

- 1 Important Electrical safety**
- 2 Technical Specifications / Appliance Dimensions**
- 3 Components**
- 4 Operating Instructions**
- 5 Maintenance**
- 6 Warranty**

1

Important Electrical safety

Read all instructions fully before using this electric fire.

This electric fire is for **INDOOR USE ONLY**.

If installing the appliance into an existing Chimney the chimney **MUST** be blocked off / capped.

Do not locate the fire below or in front of a fixed socket outlet.

Warning **DO NOT COVER** the fan heater air inlet / outlet as it could cause possible fire. Note the warning symbol on the fire.

Do not use the fire near a bath / shower / swimming pool.

Do not use the fire in areas where gasoline / paints / flammable liquids are stored, as they may catch fire.

This appliance must be securely fixed / recessed to an internal wall in the property. Keep all furniture / curtains etc as least 1 meter away from the fire.

The fire must be earthed.

After the fire's installation the plug must be accessible.

Always disconnect the power supply before any cleaning / maintenance of the appliance. Ensure the appliance is cool before proceeding.

If the power cord is damaged, it must be replaced by a qualified electrician or manufacturer service technician.

Do not run the power cord under a carpet / rug etc. Always ensure it is routed securely and it is not a trip hazard. Ensure the power cord is kept away from hot surfaces and areas.

Young children under 8 years old must always be supervised and must not play with the fire. The appliance is not a toy. Do not throw anything at the glass or strike the glass of the appliance.

The appliance must not be used by young children or the infirm, ensure a fire guard is fitted to protect from burns as the fire can get very hot.

The appliance must not be used through an external switching device such as a timer or connected to a circuit that is regularly on and off by a utility.

Do not use the appliance to dry clothes.

Do not use the appliance in small areas where there are persons are incapable of leaving the area on their own, unless there is constant supervision.

This appliance is supplied with a 13Amp 3 pin moulded plug. The fire must only be connected to a 220/240V ac supply 50/60 Hz. Please note the main power lead wires are coloured coded to UK and Irish standards, see below.

Green / Yellow (Earth / E \perp)

Blue (Neutral / N)

Brown (Live / L)

Do **NOT** operate the appliance if it is damaged.

2 Technical Specifications

Models	Trance 1250	Trance 1600
Maximum heat output	1500W	1500W
Minimum heat output	750W	750W

Heat Output per model

Voltage supply 220 / 240V 50/60Hz

Power usage for LED lighting / per model

Models	Trance 1250	Trance 1600
Flame LCD screen display output	54W	60W
Fuel Bed LED output	15W	18 W
Down lighting LED output	5W	6.6 W
Front LED pulsing lights output	2.0W	2.0 W
Mood LED lighting output	9.6W	9.6 W

Appliance Dimensions

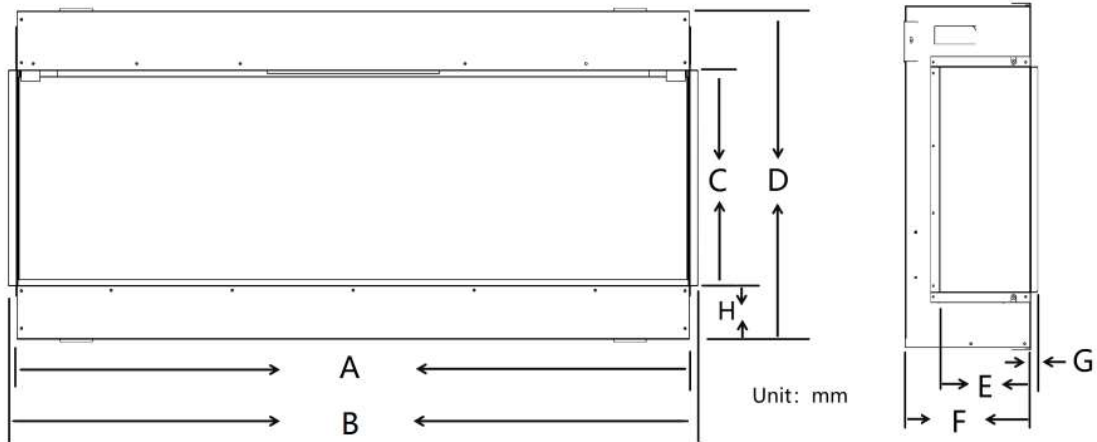

Models	A	B	C	D	E	F	G	H
Trance 1250T	1250	1282	402	611	187	251	14	99
Trance 1600T	1600	1632	402	611	187	251	14	99

Components

Before unpacking the fire inspect the carton for any damage, either caused by transport / water etc. If in doubt contact your local retailer, and do not use the appliance.

IMPORTANT

Keep any plastic packaging and small parts away from young children as they will pose a danger.

Carton Contents:

Fire Chassis (fully assembled)	quantity 1
Instruction manual	quantity 1
Remote Control and battery	quantity 1
Wall mounting bracket	quantity 1
Lower mounting brackets	quantity 2
Log set	quantity 1
Base crystals (Boxed)	quantity 1
Glass suction clamp	quantity 1

Operating Instructions

Manual Operation

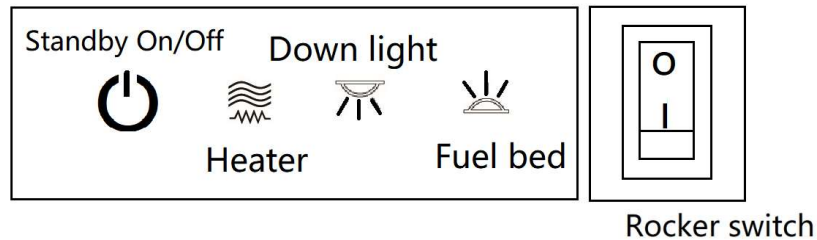

Rocker Switch

Push the rocker switch to I.

Standby button

Press the standby button once to turn the fire on (wait 15 seconds for the fire to come on). To turn the fire off press the button again.

Heater Button

Press the heater button once and the heater will turn on to half heat (750w). Press the heater button a second time and the heater increases to full heat (1500w). Press the heater button a third time and the heater will turn itself off.

Please Note: When the heater is turned on the fan will blow cold air for 30 seconds before the heating element starts.

Down Light Button

Pressing the **down light button** changes the colours. There are four different colour settings.



Fuel Bed Button

Pressing the **fuel bed button** changes the colours. There are fourteen different colour settings.

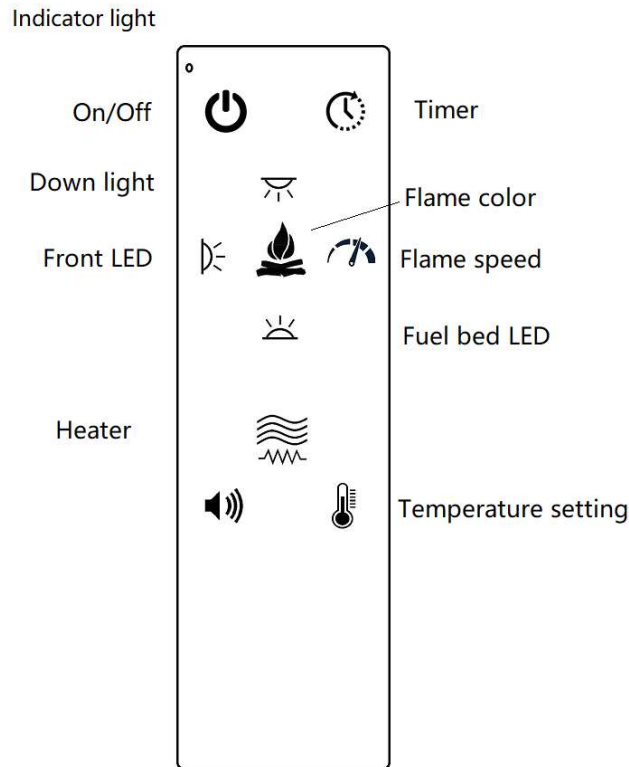
Remote Operation





1. Turning on/off the appliance

Turn the Rocker switch  to turn on the appliance. Press  to turn on or turn off the electric fire.

2. Timer

Press  button for timer setting, OFF - 60min-120min-180min-240min-300min-360min-420min-480min.

3. Electric heating control

Press  button to turn on or turn off the electric heater. Press the button once for **half** power (750 W) — twice for **full** power (1500 W)—press three times and it will turn the heater off. Turn on the heater and then press  button for set temperature.

4. Down light effect

Press  button to select the down light color.

5. Flame effect

Press  button for select flame color.

6. Front LED pulsing lights

Press  button for turn on or turn off the Front LED.

7. Fuel bed effect

Press  button for select the Fuel bed color.

8. Crackling sound

Press  button for turn on or turn off the burning sound

SPARE PARTS LISTS & CODES

ICONIC TRANCE 1250T

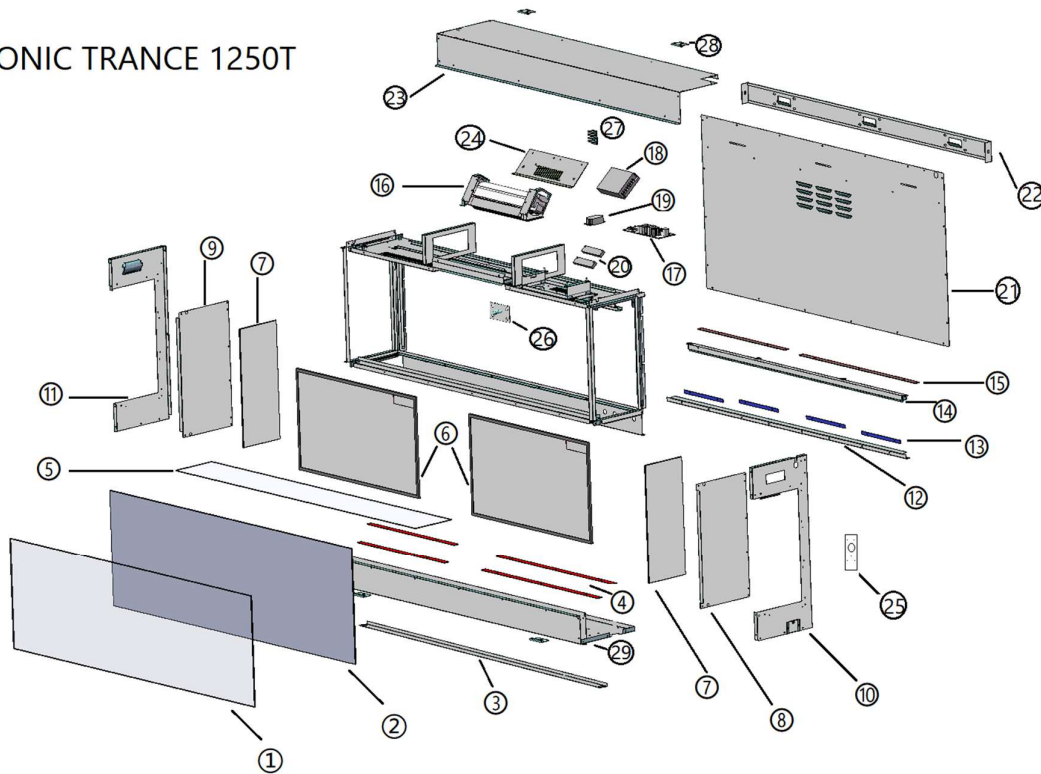

	Component	ICONIC Trance 1250T		Component	ICONIC Trance 1250T
1	Front glass	FG-1250	16	Fan Heater	FH-1250
2	Flame effect glass	FEG-1250T	17	PCB control board	PCB-Trance
3	Front glass Fixing part	FGFP-1250	18	Power supply	PW-Trance
4	Fuel bed Led	FBL-1250	19	Speaker	SP-ICONIC
5	Fuel bed board	FBB-1250	20	Power supply for Screen display	PSDD-Trance
6	LCD Screen display-27	LCD-27	21	Back plate	BP-1250T
7	Sides glass	SG-1250	22	Mounting bracket	MB-1250
8	Left cover side plate	LCSP-1250	23	Top part	TP-1250T
9	Right cover side plate	RCSP-1250	24	Power supply support bracket	PSSB-Trance
10	Left side part	LSP-1250T	25	Remote control	RM-Trance
11	Right side part	LSP-1250T	26	Remote receiver	RR-Trance
12	Front light guard part	FLGP-1250	27	LCD display signal Hub	LDSH-Trance
13	Front Led light	FLL-1250	28	Fixing bracket	FB-ICONIC
14	Down light guard part	DLGP-1250	29	Bottom part	BP-1250T
15	Led Down light	LDL-1250	30		

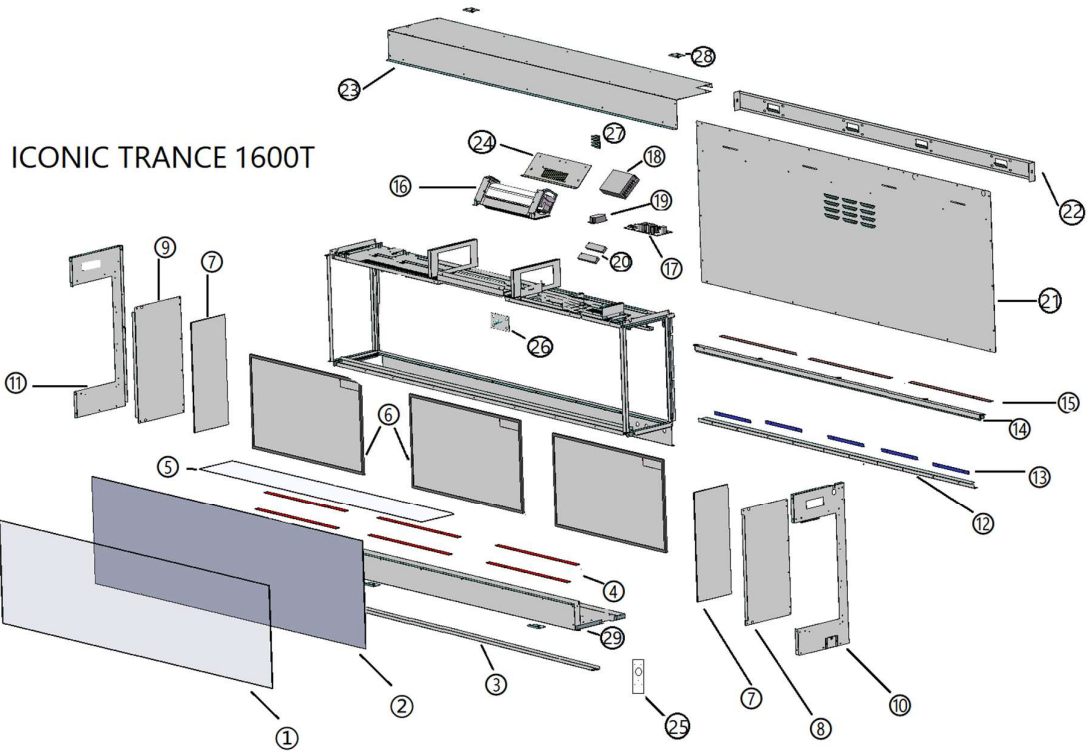

	Component	ICONIC Trance 1600T		Component	ICONIC Trance 1600T
1	Front glass	FG-1600	16	Fan Heater	FH-ICONIC
2	Flame effect glass	FEG-1600T	17	PCB control board	PCB-Trance
3	Front glass Fixing part	FGFP-1600	18	Power supply	PW-Trance
4	Fuel bed Led	FBL-1600	19	Speaker	SP-ICONIC
5	Fuel bed board	FBB-1600	20	Power supply for Screen display	PSSD-Trance
6	LCD Screen display-21.5	LCD-21.5	21	Back plate	BP-1600T
7	Sides glass	SG-1600	22	Mounting bracket	MB-1600
8	Left cover side plate	LCSP-1600	23	Top part	TP-1600T
9	Right cover side plate	RCSP-1600	24	Power supply support bracket	PSSB-Trance
10	Left side part	LSP-1600T	25	Remote control	RM-Trance
11	Right side part	RSP-1600T	26	Remote receiver	RR-Trance
12	Front light guard part	FLGP-1600	27	LCD display signal Hub	LDSH-Trance
13	Front Led light	FLL-1600	28	Fixing bracket	FB-ICONIC
14	Down light guard part	DLGP-1600	29	Bottom part	BP-1600T
15	Led Down light	LDL-1600	30		

Maintenance

Always isolate the power from the mains and ensure the fire has cooled down before any cleaning or maintenance is undertaken.

Cleaning the appliance

Carefully clean the air inlet and heater area with a cloth or vacuum on a regular basis. It is important that these areas are kept free from dust / pet hairs etc.

Do not use abrasive cleaners on the appliance.

Do not spray liquids directly onto the appliance.

When cleaning the glass spray glass cleaner onto a cloth and then clean glass, buff dry with a lint free cloth.

NOTE: The glass in the appliance is tempered for safety, if the glass receives a hard impact it will shatter, take extra care to ensure the corners of the glass do not hit a hard surface.

If removing the glass from the appliance to clean it then certain precautions need to be followed.

Wear safety gloves /glasses / ensure the glass is placed on a soft surface.

We recommend for the large 1600 (64") appliance that 2 people are needed to remove the glass.

Do not rely on the glass suction cup supplied to carry the weight of the glass, these are only for tilting the glass back so it can be removed.

Battery Replacement

Replace the battery when the battery indicator is empty on the remote. Ensure to replace with the correct type of batteries (2 X 1.5V AAA), Ensure the batteries are installed in the correct orientation.

6

Warranty

Your Iconic electric fire comes with a two-year parts and labour warranty as standard. The warranty starts from the date of purchase, if you wish to extend the warranty for an extra 12 months you must register the appliance on <https://iconicfires.com/en/warranty/> . To avail of your warranty, you must upload proof of purchase (Receipt) from your local approved Iconic retailer. The warranty is not transferable.

All warranties will be null and void if unauthorised repairs / modifications are made to the electric fire / accidently damage caused by transit / improper installation / serial numbers missing or modified.

Heat Design shall not be liable for any consequential loss or damage whatsoever arising from or in connection with this electric fire.

Service calls and installation errors are not covered under manufacturer warranty. A call out charge will apply.

This warranty is an addition and does not affect your statutory rights of consumers.

Heat Design

Unit 60, Hawthorn Road, Western Industrial Estate, Naas Road

Dublin 12.

Email Info@heatdesign.ie